

## Tools for Physiology Labs: Inexpensive Equipment for Physiological Stimulation

**Bruce R. Land, Bruce R. Johnson, Robert A. Wyttenbach, and Ronald R. Hoy**

*Department of Neurobiology and Behavior, S.G. Mudd Hall, Cornell University, Ithaca NY 14853.*

We describe the design of inexpensive equipment and software for physiological stimulation in the neurobiology teaching laboratory. The core component is a stimulus isolation unit (SIU) that uses DC-DC converters, rather than expensive high-voltage batteries, to generate isolated power at high voltage. The SIU has no offset when inactive and produces pulses up to 100 V with moderately fast (50  $\mu$ s) rise times. We also describe two methods of stimulus timing control. The first is a simplified conventional, stand-

alone analog pulse generator. The second uses a digital microcontroller interfaced with a personal computer. The SIU has performed well and withstood intensive use in our undergraduate physiology laboratory. This project is part of our ongoing effort to make reliable low-cost physiology equipment available for both student teaching and faculty research laboratories.

*Key words: stimulus isolation, timing control*

The cost of physiological equipment sometimes prevents integrating neurophysiology exercises into undergraduate physiology laboratories. Similarly, faculty with limited budgets may not consider electrophysiological approaches to their research. To reduce budgetary barriers, we are designing inexpensive instruments that can be built by faculty or support staff, or even as student projects. We have previously presented a low-cost, high-performance amplifier and suction electrode for extracellular nerve recording and stimulation (Land et al., 2001). Here we describe inexpensive equipment and software that we use for nerve stimulation in our student physiology laboratories.

Electrical stimulation of nervous tissue has been an essential experimental tool since the early days of neurophysiology (Katz, 1966). In the student laboratory, electrical stimuli are used to examine action potential conduction and synaptic transmission, among other topics (e.g. Oakley and Schafer, 1978; Olivo, 2003; Paul, 1997; Wyttenbach et al., 1999).

The core component of our stimulation equipment is a stimulus isolation unit (SIU). When the output of an electronic pulse generator or computer D/A output is applied directly to a biological preparation, it can cause electrical noise in the recording system, add a large DC offset, and produce a stimulus artifact that obscures the smaller biological signal under study. To reduce these recording problems, an SIU isolates the stimulus ground from the equipment ground. The stimulus current travels from the positive pole of the SIU through the biological tissue, and then to the negative pole of the SIU, bypassing the ground of the recording electrode. Furthermore, most pulse generators and A/D cards are limited to 10 V output, insufficient to stimulate many preparations. An SIU provides the needed power.

An SIU for the teaching lab should have the following characteristics: (1) Isolation over 1 G $\Omega$  and capacitive coupling under 20 pF. This keeps current leaking to the recording apparatus small compared to the biologically produced currents. (2) Variable output of 0 to 100 V, supplying about one Watt of power (10 mA at 100 V). This is comparable to commercial units and provides enough current to stimulate most preparations. (3) Powered by line

voltage instead of batteries. Many older SIUs require expensive high-voltage batteries that are now hard to find; using line voltage saves battery replacement time and cost. (4) Output controlled by a logic-level pulse with the desired timing from another analog or digital device.

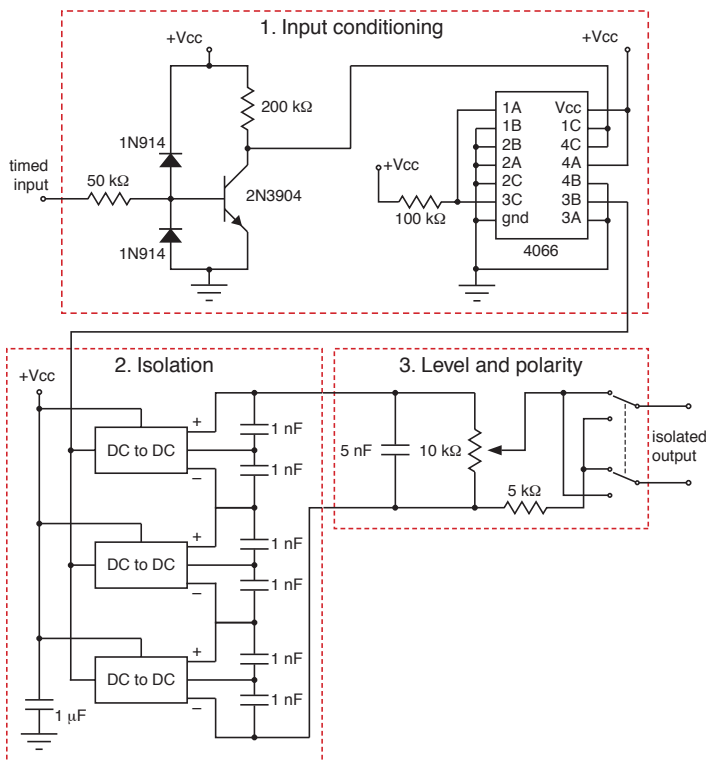
Stimulus isolation in battery-powered SIUs has been traditionally achieved using optocouplers. Our design instead uses commercially available DC-to-DC converters as isolated power supplies, bypassing the need for batteries. Our SIU is similar to one developed independently by Brasil and Leal-Cardoso (1999), but ours uses less complicated circuitry and produces a lower voltage output. The output timing of a SIU must be controlled with specific commands to elicit neural responses. We describe two methods to control pulse timing. Both are easy for students to use; can produce single pulses, pairs of pulses, and trains of pulses; have wide ranges of pulse rates and durations; have variable delay for single pulses; and allow manual triggering of single pulses. The first design is a low-cost, conventional analog pulse generator. The second uses a PC to produce a convenient user interface and a microcontroller to generate accurately timed pulses to trigger the SIU.

## METHODS

### *Stimulus Isolation Unit*

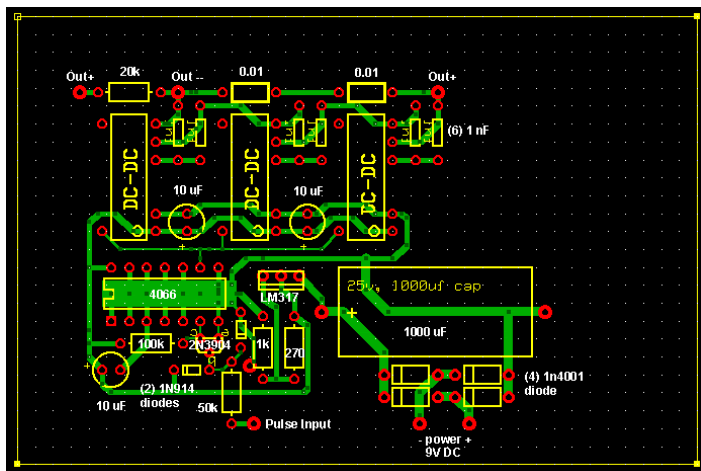
The SIU circuit (Fig. 1) is based on commercially available isolated DC-to-DC converters. These can be turned on and off in about 50  $\mu$ s. When on, each converter becomes a 30 V, 1 W voltage source. When off, they are passive with no offset voltage. Several DC-to-DC converters may be connected in series to produce higher voltages.

The SIU has three sections: (1) input conditioning, (2) isolation and voltage increase, and (3) output level and polarity control. The first section uses an input logic level pulse (3 to 12 V) to drive the control inputs of the DC-to-DC converters. The input transistor and diodes protect the circuit from large voltage transients. These limit, amplify, and invert the input pulse. The output of the transistor is a logic-level pulse suitable for driving a CMOS quad transmission gate (4066). A high voltage at the pulse input results in a low voltage at the output of the transistor, which

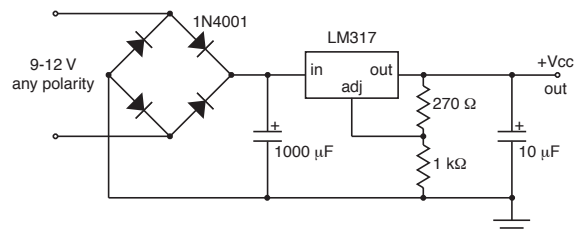


**Figure 1.** Stimulus isolation unit. See text for a description of the three stages. +Vcc indicates power supply input; see Fig. 3 for a recommended power conditioning circuit.

turns off the CMOS transmission gate and turns on the converters in stage 2. All unused inputs to the 4066 must be grounded because CMOS gates tend to draw current if their inputs are unconnected. The second stage uses one or more Burr-Brown DCP010515D DC-to-DC converters. Each converter produces 30 V output with a 6 V power supply. We used three connected in series to produce 90-100 V. *Caution:* The series output may cause injury if touched; use care with all high voltage sources. The 1 nF capacitors should be connected close to each converter to suppress the 400 kHz switching noise from the converters. The third stage is a voltage divider to set the stimulus output level and a switch to control stimulus polarity. In



**Figure 2.** SIU layout. This printed circuit board includes the circuit shown in Figure 1 and the power conditioning shown in Figure 3 with two additional capacitors between Vcc and ground.



**Figure 3.** Power conditioning. Input is any voltage from 9-12 V in either polarity; output is a regulated 6 V.

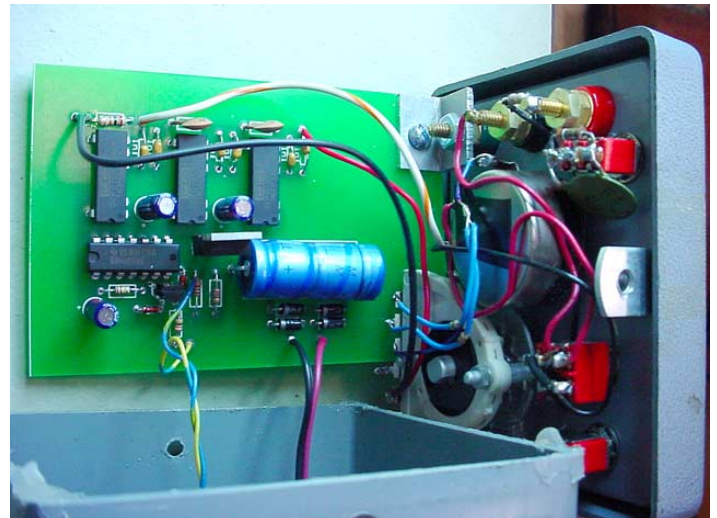
addition to controlling output level, the 10 kΩ potentiometer works with the 5 nF capacitor to form a low-pass filter that further reduces switching noise from the converters.

Figure 2 shows a printed circuit board layout for the SIU, including power conditioning shown in Figure 3. The 4066 CMOS transmission gate is kept away from the converter outputs to reduce capacitive coupling to ground. The 1 nF capacitors are as close as possible to the converter outputs. The SIU should be built in a plastic box to reduce capacitive coupling to ground. Figure 4 shows the circuit board with all parts in place and front-panel controls attached. With the power conditioning circuit, the SIU can be powered by any 9-12 V 300 mA source. The cost of parts for the SIU is about \$50.

#### Analog Pulse Generator

An SIU must be controlled by a device that produces logic-level pulses with the desired timing. The main timing features needed for single pulses are delay after the stimulus command initiation, pulse duration, repeat time, and a synch output to trigger other devices such as oscilloscopes. For double pulses and pulse trains, the pulse interval and train duration must be specified. Note that any pulse timer can control the SIU. If a pulse generator is already available (included with many data acquisition software packages), there is no need to build either of the pulse generation circuits described next.

We first describe our simplified design for an analog timer to control SIU output. The circuit shown in Figure 5 uses a 555 timer chip in each of three sections to control pulse rate, delay, and duration. Timing is determined by



**Figure 4.** SIU construction. The circuit was placed in the housing of an obsolete WPI SIU, using its switches and jacks.

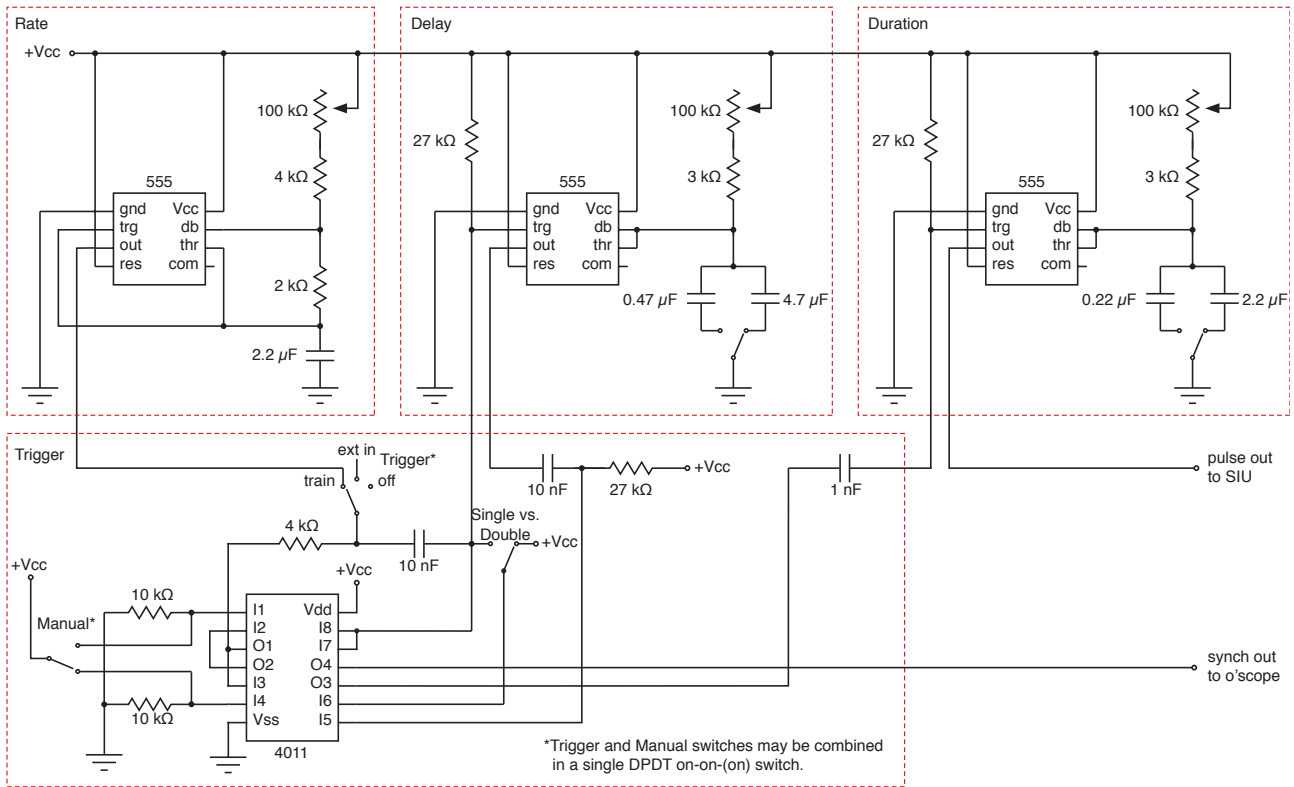


Figure 5. Analog pulse generator. See text for a description of the four sections.

the capacitors and variable resistors in each section of the circuit. With the values shown in Figure 5, the pulse generator has ranges of 20-220 ms pulse period, 0-470 ms delay, and 0-220 ms duration. Increasing the size of the capacitor connected to the THR pin of the 555 timer linearly increases these times. For example, changing the 0.47 and 4.7 μF capacitors to 1 and 10 μF would increase maximum delay to 1 s. The first timer controls the pulse rate if the stimulator is in train mode, and is disconnected otherwise. The second timer controls the pulse delay (time between synch out and pulse out) in single pulse mode and controls the spacing of two pulses in dual pulse mode. The third timer controls pulse duration. A fourth section manages triggering, produces a synch output for an oscilloscope, and conditions a pushbutton for manual triggering. The 4011 quad-AND gate ensures only one

pulse is produced when the manual switch is activated. This section also selects between single and double pulses. A train of pulses with a specific duration would have to be manually timed. Figure 6 shows the layout of the circuit on a printed circuit board. A working model is shown in Figure 7. Power is from a 9 V battery, with current draw from the battery around 6 mA. A standard 9 V battery should last for around 100 hours with this use. Most of the approximately \$35 cost of parts comes from the switches and variable resistors.

*Microcontroller Pulse Generator*

Somewhat more sophisticated stimulus timing at lower cost can be achieved by a microcontroller circuit operated by a

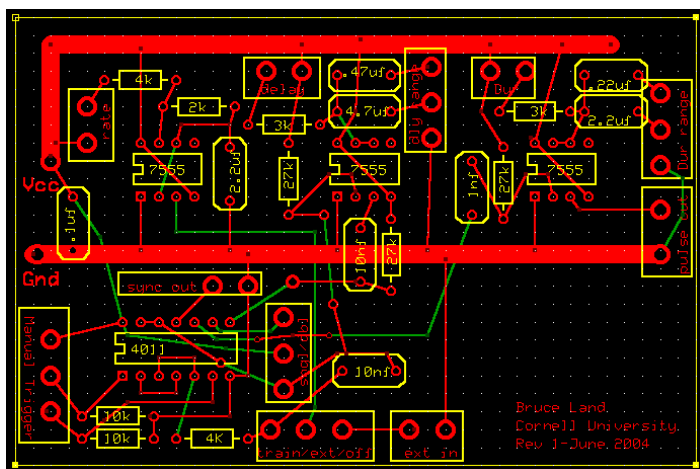


Figure 6. Analog pulse generator layout.

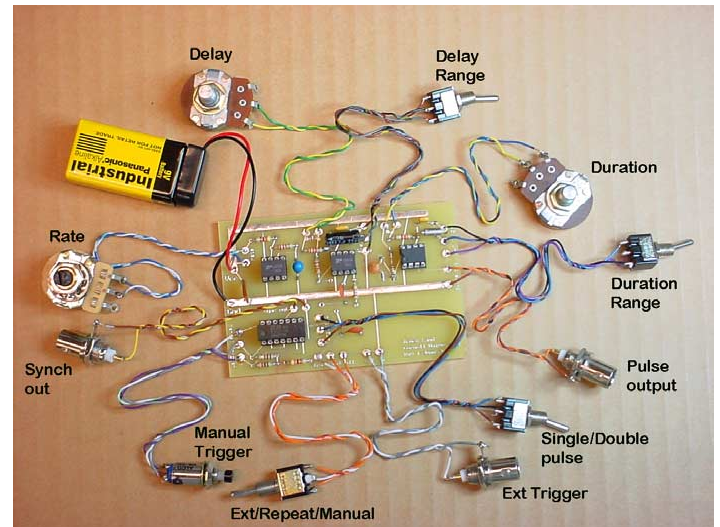


Figure 7. Analog pulse generator construction.

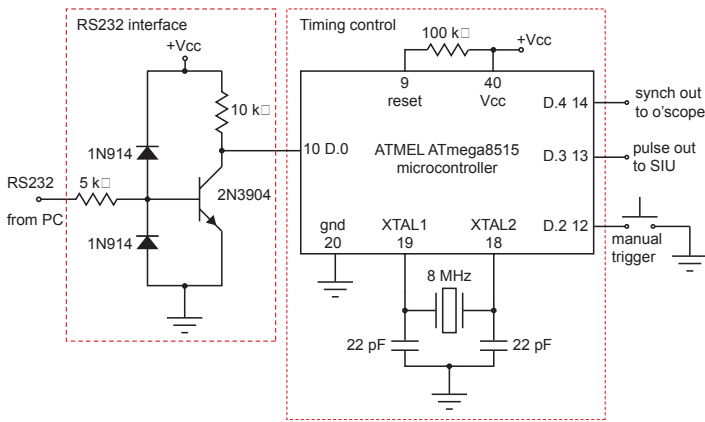


Figure 8. Microcontroller pulse generator.

graphic user interface (GUI) on a PC. We designed this pulse generator to: (1) produce 1 to 255 pulses in a stimulus train, (2) repeat the train at fixed intervals up to 2 seconds, or once by pushbutton, (3) produce pulses from 0.1 ms to 2 s duration, and (4) have pulse intervals of 0.1 ms to 2 s. Using a microcontroller as a real-time buffer between the PC-controlled user interface and the isolator allowed us to keep timing accuracy high and cost low.

The circuit is shown in Figure 8. Software running on a PC sends simple text commands from the serial port to the microcontroller to set pulse timing. A transistor inverts the incoming RS232 signal and passes it to the microcontroller. The microcontroller is timed by an 8 MHz crystal, with the reset line tied to the supply voltage. The 8 MHz clock yields an overflow time of 32  $\mu$ s for timer 0, which becomes the resolution of the pulse width. There is also a manual trigger pushbutton connected from pin D2 to ground, with an internal resistor turned on by software to drive the pushbutton. Two outputs control the stimulus. Port pin D.3 is toggled by the timer 0 interrupt service routine to control pulse timing. This pulse output is used to control the SIU. Port pin D.4 is the synch pulse output for connection to an oscilloscope or other recording device. Figure 9 illustrates the layout of the microcontroller timer on a printed circuit board and Figure 10 shows a working model of this timer. This circuit is powered by a 9 V battery and should run at least 60 hours on a battery, drawing

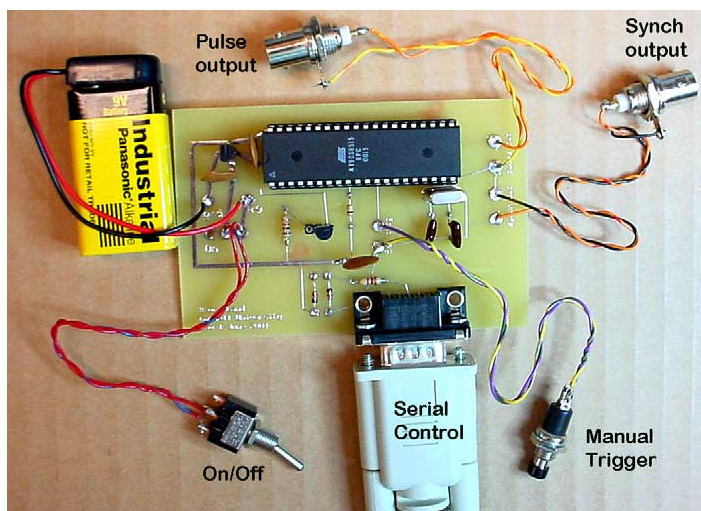


Figure 10. Microcontroller construction.

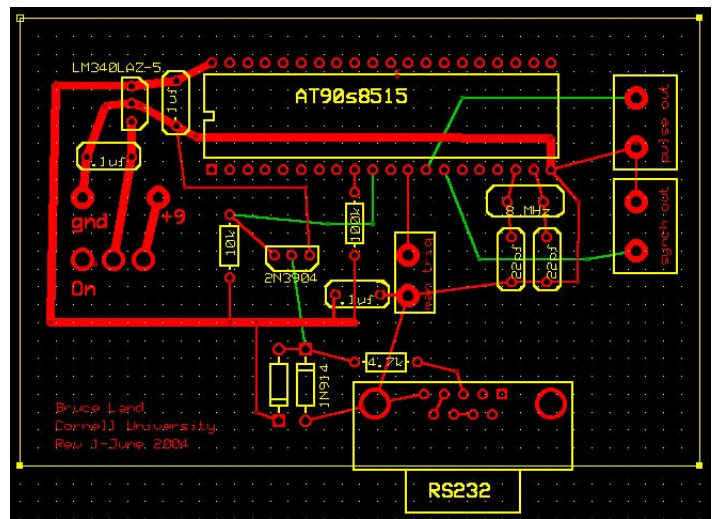


Figure 9. Microcontroller circuit board layout.

around 16 mA. The cost of parts is about \$20. Construction of the microcontroller pulse generator is simpler than the analog version because there are fewer parts.

The microcontroller itself must be programmed once before use. This is done by downloading code onto the chip with a reusable kit available from ATMEL for \$79 (<http://crawdad.cornell.edu/stim/> has the required code and links to ATMEL hardware and software).

Any software could be used to send commands to the microcontroller. We wrote a MatLab (mathworks.com) program to do this. Four text-entry fields and a few pushbuttons control the stimulator (Figure 11). The program structure is simple: define the controls, then enter an event loop and wait for controls to be touched. Each control has a callback function that does range checking and sets an execution flag. The main loop formats strings, based on the numerical contents of the various text-entry fields, and sends them to the microcontroller. The program handles unit conversion and prevents changes in the parameters during pulse train generation. The GUI and microcontroller can be started in any order because the 8515 waits for a command from the GUI and the GUI sends only self-contained commands. If the microcontroller power is turned off and on while it is actually receiving a command, it may end up in an indeterminate state. This can be fixed by simply turning the device off and on again, and should never happen in normal use. MatLab code and microcontroller commands are available at our web site.

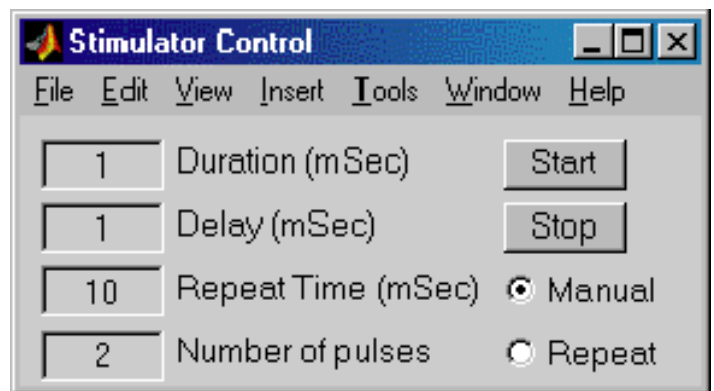
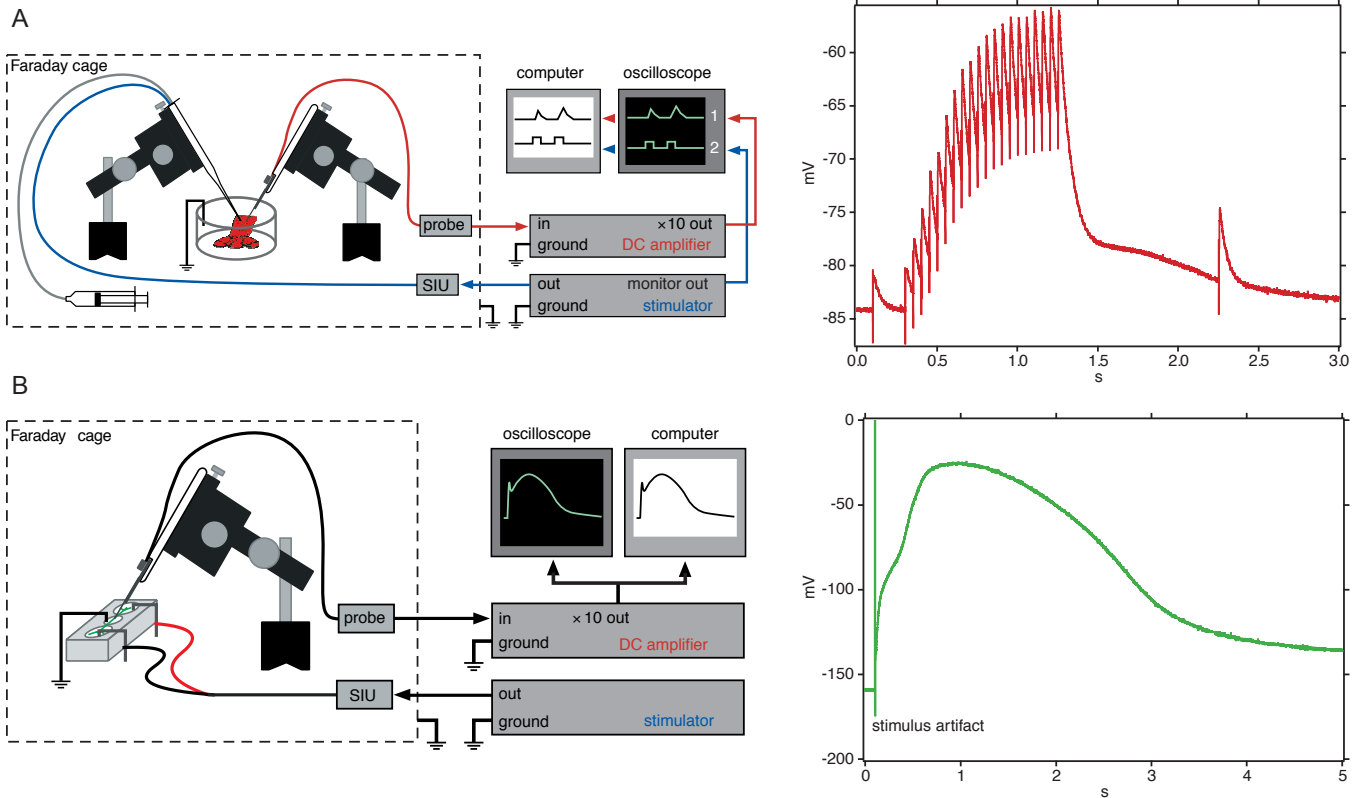


Figure 11. Interface to microcontroller.



**Figure 12.** Example SIU use. A) Recording setup and data from crayfish muscle when the motor nerve is stimulated. B) Recording setup and data from extracellular stimulation of a single cell of the alga *Chara*.

With the circuit described above, stimulus amplitude is controlled by the SIU. An alternative design allows the GUI to control amplitude but only works for SIU output under 25 V; the modified circuit is on our web site.

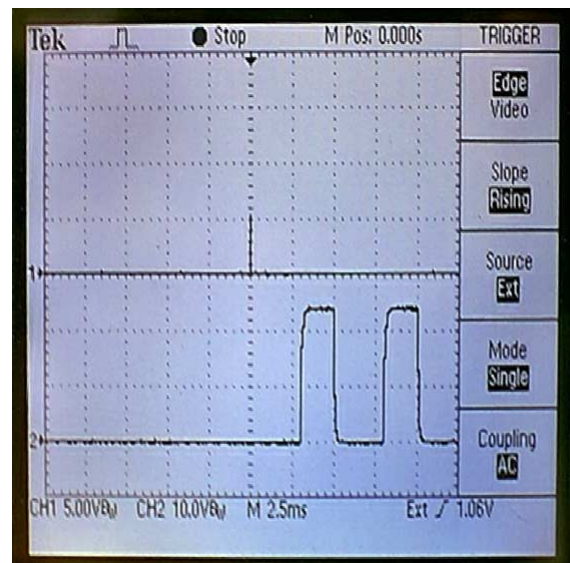
**RESULTS**

*SIU Performance*

The SIU described above has been used extensively for two years by undergraduate students taking Principles of Neurophysiology (BioNB 491) and by students who include electrophysiology as part of their research projects at Cornell University. Examples of data gathered by students using our SIU are shown in Figure 12. Nerve 3 of the crayfish abdominal ganglia is a purely motor nerve that innervates the superficial flexor muscle of the tail. This is a slow postural muscle that does not fire action potentials. A standard student electrophysiological set-up was used to intracellularly record excitatory post-synaptic potentials (EPSPs) elicited by stimulation of nerve 3 through a suction electrode (Land et al., 2001). This example shows a train of pulses preceded and followed by test pulses, illustrating synaptic potentiation (Fig. 12a). A second example is shown in Figure 12b, where a single cell of the alga *Chara* was extracellularly stimulated to fire the action potential recorded intracellularly. Both recordings show stimulus artifact comparable to that produced by commercial SIUs. The size of artifact depends on the duration and amplitude of stimulus necessary to elicit a response. For details of the two student preparations, see Wyttenbach et al. (1999) and Johnson et al. (2002). In these examples, stimulus timing was controlled by StimScope, our MatLab-based data acquisition and analysis software (Land et al., 2002).

*Pulse Generator Performance*

Figure 13 shows a frame taken from one of two videos demonstrating features of the analog and microcontroller timing control devices. The top trace shows the 2 μs synch pulse; the lower trace shows output of the SIU controlled by the pulse generator. Pulse duration was set to 2 ms and delay to 3 ms. For the microcontroller-based device, durations and delay times were no more than 4% off from times set in the GUI. Rise times of the pulses varied from 40 to 70 μs with amplitude.



**Figure 13.** Pulse generator performance. This is one frame of a video (see <http://crawdad.cornell.edu/stim>) showing timing output on an oscilloscope. The x-axis is 2.5 ms/division.

## DISCUSSION

The SIU and pulse generator designs described here are targeted for use in student laboratories and for faculty research, especially when equipment cost is a factor in the choice of teaching exercise or research approach. We look for electronic components that incorporate recent technical innovations that make circuits simpler, smaller, and lower cost, with good performance in the teaching laboratory (see also Land et al., 2001). For example, our 100 V SIU has an estimated cost of \$50-100, depending on the quality of the switches used. This is the less than the cost of two sets of batteries for the commercial isolators we previously used. The total component cost of both the analog and microcontroller pulse generators is even less. One could easily spend ten times as much for commercial products.

Similar designs for physiological stimulation equipment found in the literature are often more complex than needed for student use. Our SIU differs from that of Brasil and Leal-Cardoso (1999) in that: (1) The voltage output is lower since our design is intended for more restricted nerve stimulation. (2) We used the simplest possible circuitry to minimize cost, at the expense of rise time (insignificant for student use). (3) We did not attempt to provide constant-current output. Our analog stimulator design is based on the classical Grass S-9 stimulator circuitry, but with 555 timer chips replacing vacuum tube one-shots. The 555 timer circuits are well known from manufacturer's data sheets (e.g. Maxim Integrated Products, 1992). There are many computer-based pulse generators (e.g. Cheever et al., 1998; Jaw et al., 1995); ours implements only the basic functions required in the teaching lab.

Our SIU has proven reliable and durable through several years of student use. It is an essential component of electrophysiological rigs for our *Crawdad* exercises, in which students model passive properties of membranes, investigate synaptic transmission, and stimulate action potentials in a plant cell (Wytenbach et al., 1999). In addition, our students have used the SIU to determine conduction velocities in nerve bundles and examine giant fibers in crayfish nerve cords. It should be useful for any type of student neuroscience exercise, physiological or anatomical, that requires timed electrical stimuli.

## PART LISTS

SIU with power conditioning (quantity in parentheses if more than one required): 1N4001 diode (4); 1N914 diode (2); LM317 voltage regulator; 4066 quad CMOS gate; 2N3904 transistor; Burr-Brown DCP010515D DC-to-DC converter (3); 1000  $\mu$ F, 10  $\mu$ F, 1  $\mu$ F, 5 nF, 1 nF (6) capacitors; 270  $\Omega$ , 1 k $\Omega$ , 5 k $\Omega$ , 10 k $\Omega$ , 50 k $\Omega$ , 100 k $\Omega$ , 200 k $\Omega$  resistors; DPDT toggle switch.

Analog pulse generator: 555 timer chip (3); 4011 quad AND gate; 1 nF, 10 nF (2), 0.22  $\mu$ F, 0.47  $\mu$ F, 2.2  $\mu$ F (2), 4.7  $\mu$ F capacitors; 2 k $\Omega$ , 3 k $\Omega$  (2), 4 k $\Omega$  (2), 10 k $\Omega$  (2), 27 k $\Omega$  (3) resistors; 100 k $\Omega$  potentiometers (3); SPDT toggle switch (4); SPDT on-off-on toggle switch.

Microcontroller pulse generator: 1N914 diode (2); 2N3904 transistor; ATMEL ATmega8515 microcontroller; 8 MHz crystal; 22 pF capacitor (2); 5 k $\Omega$ , 10 k $\Omega$ , 100 k $\Omega$  resistors; SPST pushbutton switch.

## NOTE

See <http://crawdad.cornell.edu/stim/> for part lists and sources, printed circuit board designs, MatLab code for the microcontroller GUI, ATMEL microcontroller code, and general information about building circuits.

## REFERENCES

- Brasil RO, Leal-Cardoso JH (1999) An optically coupled power stimulus isolation unit with high voltage and fast rise time output. *Braz J Med Biol Res* 32:767-771.
- Cheever EA, Thompson DR, Cmolik BL, Santamore WP, George DT (1998) A versatile microprocessor-based multichannel stimulator for skeletal muscle cardiac assist. *IEEE Trans Biomed Eng* 45:56-67.
- Jaw FS, Liu S.J., Kuo TS, Wang CY (1995) Microcomputer-based pulse stimulator. *J Neurosci Meth* 62:193-197.
- Johnson BR, Wytenbach RA, Wayne R, Hoy RR (2002) Action potentials in a giant algal cell: a comparative approach to mechanisms and evolution of excitability. *J Undergrad Neurosci* 1:A23-A27.
- Katz B (1966) *Nerve, Muscle and Synapse*. New York: McGraw-Hill Book Company.
- Land BR, Wytenbach RA, Johnson BR (2001) Tools for the student physiology lab: An inexpensive high-performance amplifier and suction electrode for extracellular recording. *J Neurosci Meth* 106:47-55.
- Land BR, Johnson BR, Wytenbach RA, Hoy, RR (2002) Stimscope: A virtual instrument for neurophysiology in the teaching lab. *Soc Neurosci Abstr* 28:22.68.
- Maxim Integrated Products (1992) General purpose timers. <http://pdfserv.maxim-ic.com/en/ds/ICM7555-ICM7556.pdf>
- Oakley B, Schafer R (1978) *Experimental Neurobiology: A Laboratory Manual*. Ann Arbor, MI: University of Michigan Press.
- Olivo RF (2003) An online manual for neurophysiology. *J Undergrad Neurosci* 2:A16-A22.
- Paul CA (1997) *Discovering Neurons: The Experimental Basis of Neuroscience*. Cold Spring Harbor, NY: Cold Spring Harbor Laboratory Press.
- Wytenbach RA, Johnson BR, Hoy RR (1999) *Crawdad: A CD-ROM Lab Manual for Neurophysiology*. Sunderland, MA: Sinauer Associates.

Received August 23, 2004; revised October 06, 2004; accepted October 08, 2004.

Development of this equipment was supported by National Science Foundation grant 955095, the Howard Hughes Medical Institute, and the Department of Neurobiology and Behavior at Cornell University.

Address correspondence to: Dr. Bruce R. Johnson, Department of Neurobiology and Behavior, S.G. Mudd Hall, Cornell University, Ithaca, NY 14853. E-mail: brj1@cornell.edu